

English

Placement Test

8th & 9th Grades (Units 61-96)



Please Return Completed Tests to:

Bridgeway Academy

334 Second Street

Catasauqua, PA 18032

Phone: 610-266-9016

Email: info@bridgewayacademy.com

Please do not read to your student.

Placement Test Instructions and Results

English 8th & 9th

Student Name: _____

Birth date: _____ Age: _____ Grade Level: _____

Testing date: _____

Where to begin:

Please begin with the first unit of this test and continue until the student scores below minimum score on 3 consecutive units. Be sure to look beyond units where the student stops to ensure that there is nothing more he or she can complete.

Scoring:

Please use the answer sheet to score your student's test and circle, on the chart below, the numbers of any units where the student scored below the minimum score.

Place a / over the number where the student stopped.

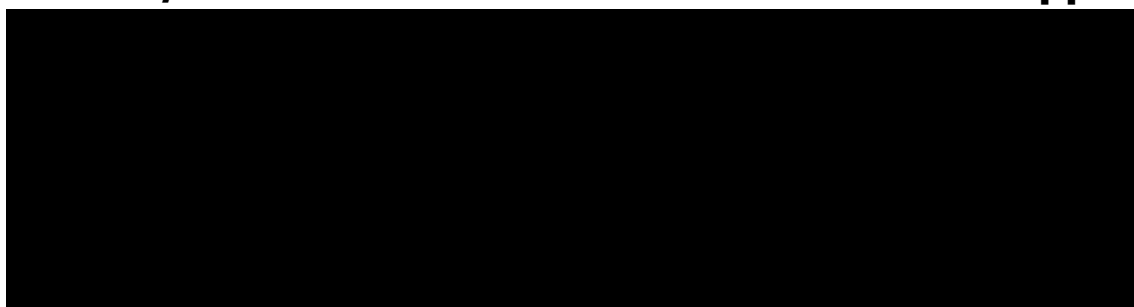

61	62	63	64	65	66	67	68	69	70	71	72
73	74	75	76	77	78	79	80	81	82	83	84
85	86	87	88	89	90	91	92	93	94	95	96

Units prescribed for student: _____

(Office Use Only)

Using the guide words below, underline the words which would be considered entry words on this dictionary page.

fair	fill
------	------

- (1) fox (3) feet (5) fix (7) fool (9) fish
(2) far (4) fail (6) flaw (8) fate (10) fall

(11) Circle the word in the list that is not in alphabetical order.

bear beet blast big brag burst

Draw one line under the simple subject and two lines under the simple predicate in each sentence. Then, draw a line dividing the complete subject from the complete predicate.

(12) The boy went downtown.

(13) Dogs are running wild.

Label the following pairs of words as “syn” for synonyms, “ant” for antonyms, “hom” for homonyms, or “het” for heteronyms

(14) _____ chord—cord (16) _____ sweet—sour

(15) _____ lead-lead (17) _____ tale—story

Unit # 61 Mastery Score: 17 Minimum Score: 15 Score _____

Form the following singular nouns.

singular singular possessive plural plural possessive

(1-3) arm _____ _____ _____

(4-6) house _____ _____ _____

(7-9) student _____ _____ _____

Underline all three nouns in the following sentences.

(10-12) The group, Acapella, sings without music

(13-15) The students drove their new truck to the convention.

Unit # 62 Mastery Score: 15 Minimum Score: 12 Score _____

Draw two lines under the verb in each sentence. Label it *AV* for action verb or *LV* for linking verb. Draw one line under and label the direct objects "*DO*", draw one line under and label the indirect objects "*IO*", draw one line under and label the predicate nouns "*PN*", and draw one line under and label the predicate adjectives, "*PA*".

- (1-2) David drove his car to the meeting.
- (3-5) Mark gave me the soda when he heard me coughing.
- (6-7) The soda was a Sprite.
- (8-9) Sprite is much too sweet.

Diagram the following sentences.

- (10) The dog ate his food.

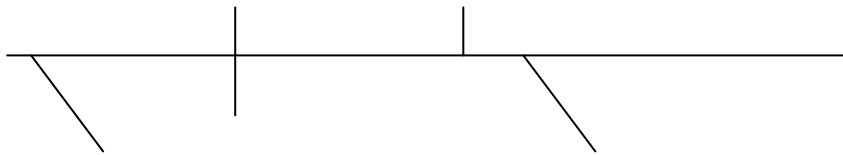

- (11) My chair is broken



Unit # 63 Mastery Score: 11 Minimum Score: 9 Score _____
--

Underline the subjective case pronouns in the following sentences.

- (1) Grandpa, you should have seen the fish I caught yesterday.
- (2) It was a rainy day but the fish were hungry.
- (3) They were tugging on our fishing line.

Underline the objective case pronouns in the following sentences.

- (4) Sharon went to the grocery store with mother and me.
- (5) It was nice to have my big sister go to the store with us.
- (6) Mother bought her a new mop for her new home.

Underline the possessive case pronouns in the following sentences.

- (7) I am thankful for my grandparents.
- (8) They are willing to share their home with others.
- (9) This same kind of hospitality can be yours, too.

Underline the interrogative pronoun.

- (10) Which book belongs to Joey?

Underline the relative pronoun.

- (11) The book that I have is the same as Joey's.

Underline the demonstrative pronoun.

- (12) These books are the same.

Unit # 64 Mastery Score: 12 Minimum Score: 9 Score _____
--

Complete this chart by giving the missing forms of these verbs.

	<u>Present</u>	<u>Present Participle</u>	<u>Past</u>	<u>Past Participle</u>
(1-2)	talk	_____	talked	_____
(3-4)	_____	asking	_____	have asked

Fill in each blank with the tense of the verb indicated.

- (5) Jenny _____ an oral report on Friday. past tense of “give”
 (6) She _____ to earn an award. present tense of “want”
 (7) She and her parents _____ a concert. past tense of “attend”

Draw two lines under the verb in each sentence. On the line write “present”, “past”, or “future” to indicate the tense of the verb.

- (8-9) Years ago, the Wright brothers built the first airplane. _____
 (10-11) Adam wants a cookie after his meal. _____
 (12-13) Mary is going to the store with Mother. _____

Complete the chart by giving the missing forms of these verbs.

	<u>Present</u>	<u>Present Participle</u>	<u>Past</u>	<u>Past Participle</u>
(14-15)	freeze	(were) freezing	_____	(has) _____
(16-17)	get	(am) getting	_____	(had) _____
(18-19)	go	(is) going	_____	(have) _____
(20-21)	know	(are) knowing	_____	(has) _____

<p>Unit # 65 Mastery Score: 21 Minimum Score: 17 Score _____</p>
--

Underline the correct verb in the following sentences. Be sure your verb agrees with the subject.

- (1) My mother (is, are) a wonderful person.
- (2) She always (take, takes) time out of her day when we need her.
- (3) We (are, am) grateful to have her.
- (4) All of my brothers and sisters and I (say, says) she is our best friend.
- (5) An empty film case was (sitting, setting) on my dresser.
- (6) Hundreds of coins (lie, lay) on my closet floor.
- (7) Hot air (raises, rises); cold does not.
- (8) The group of children (was, were) running down the hall.
- (9) Fruit, vegetables, fish, and chicken (are, is) good for you.
- (10) All flowers (make, makes) me sneeze.

Unit # 66 Mastery Score: 10 Minimum Score: 8 Score _____
--

Underline all of the adjectives including articles in the following sentences.

- (1-8) The sweet, little, blond girl with the big blue eyes sang in the festival.
- (9-11) The silver coins fell out of her wallet when she dropped it.

Underline all of the adverbs in the following sentences.

- (12) Eating quickly, the boys rushed to beat the crowds.
- (13) They wanted to be safely seated before the game started.
- (14) The team can play better when they are at home.

Underline the conjunctions and interjections in the following sentences.

(15) Yikes! We're going to be late.

(16) We did our best to be on time but the traffic was terrible.

Underline the prepositional phrases. There are two in each sentence.

(17-18) I sat beside the pitcher on the bus

(19-20) We read about him in a news story.

Unit # 67

Mastery Score: 20

Minimum Score: 16

Score _____

Label the underlined word with its part of speech (noun, pronoun, verb, adjective, adverb).

(1) _____. Michael is now the youngest child in our family.

(2) _____. He has two sisters.

(3) _____. When he cries, he cries so softly that we don't hear him.

(4) _____. His Mom and Dad were excited when he was born.

(5) _____. They called everyone to share the awesome news.

Label the underlined word with its part of speech (interjection, preposition, conjunction).

(6) _____. Help! My flashlight went out; I can't see!

(7) _____. These batteries came with the flashlight when I bought it yesterday.

(8) _____. I guess using it all night last night and tonight wore them out.

Diagram the following sentences. Be sure to place all of the modifiers under the word they are describing.

(9-13) The baby can drink her milk from a cup.

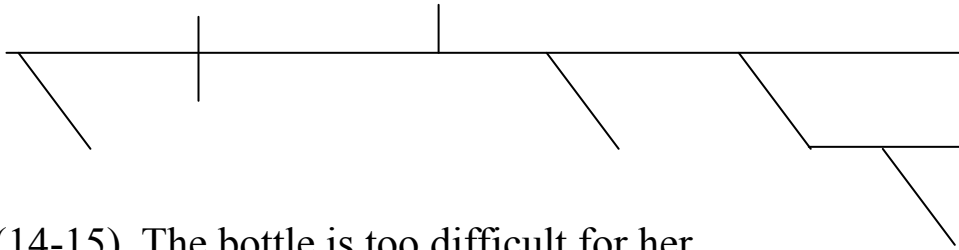

(14-15) The bottle is too difficult for her.

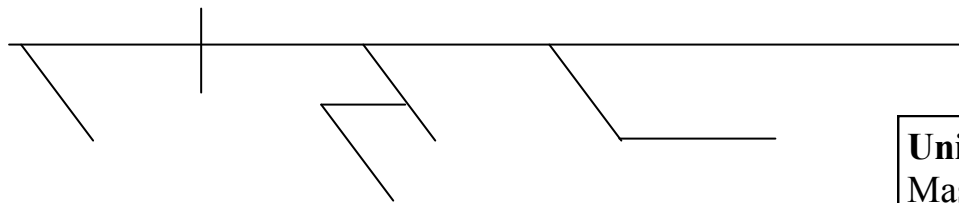

Unit # 68 Mastery Score: 17 Minimum Score: 14 Score _____

Proofread the following paragraph. Correct capitalization and punctuation (quotation marks, end punctuation, semi-colons, colons, apostrophes, commas) errors. There are two sets of quotation marks, six capitalization changes, one colon, one semi-colon, one apostrophe, one exclamation point, one comma and three periods needed.

my teacher is convinced that I can do anything. She said, You are too talented to sit around and twiddle your thumbs—it is time to get busy I was surprised that she was so sure about it. she made me memorize the following speeches the declaration of independence Patrick henry’s speech and the commencement address that C.S. Lewis gave. Lewis speech was the easiest he simply said, Try, try, try I guess that was the message she really wanted me to get

Unit # 69 Mastery Score: 16 Minimum Score: 13 Score _____

Underline the prepositional phrase in each sentence. On the line, indicate whether it is used as an adjective or and adverb.

(1) _____ . I made the chicken in the oven.

(2) (a) _____. The sauce for the chicken is a white cream sauce made with cheese

(b) _____

Underline the three clauses in the following sentence.

(3-5) I pounded the chicken first, then browned it on the stove before I put it in the oven.

Underline the topic sentence of the following paragraph.

(6) No matter what we do, the fish in our tank keep dying. We feed them every day, clean the tank twice a month and always watch for algae. We even bought two bottom feeders to try to keep things clean. But we still must be doing something wrong because Bubba, our oldest fish, died this morning.

Unit # 70 Mastery Score: 7 Minimum Score: 6 Score _____

Underline the prepositional phrase in each sentence. On the line write “adjective” or “adverb” to indicate how it is used.

(1-2) The flowers of spring smell lovely. _____

(3-4) We saw a field of yellow daisies. _____

(5-6) The weeds grew in the yard. _____

Underline the two clauses in this sentence.

(7-8) Willie sped down the hill on his bike, and Spike raced along behind.

In each sentence, underline the special introductory word and clause that follows it.

(9) Patience and perseverance are two character traits which I want to learn.

(10) Our teacher is the one who will speak next.

Underline the topic sentence of this paragraph.

(11) Katie was always a good girl. She always tried to be obedient to her parents, and was kind to the other children at the playground. She would help elderly neighbors with their

Unit # 71 Mastery Score: 11 Minimum Score: 9 Score _____
--

Organize the following pre-writing lists into an organized outline by placing letters and numbers where necessary.

New Brunswick, Canada

- I] New Brunswick has two geographical regions
- A) Both have many rivers and streams
 - 1) Appalachian Region
 - a) Contains wooded hills and valleys
 - Coastal Lowlands
 - Flat
- 1410 miles of coastline
- Atlantic Ocean
 - Bay of Fundy
 - Gulf of St. Lawrence
 - Chaleur Bay

New Brunswick has some interesting features

Tides

- Highest tides on the earth occur in the Bay of Fundy
- Water depth rises 70 feet

Reversing Falls rapids

- The Saint John river flows backwards over a series of low falls

Some of the most important things in New Brunswick

St. Johns River

- Source is the U.S. state of Maine

Economics

- Mining

- Zinc

- Lead

- Potash

- Lumbering

- Fishing

- Tourism

Capital

- Frederickton

Largest City

- St. Johns

Unit # 72

Mastery Score: 28

Minimum Score: 23

Score _____

On the line, identify whether the group of words is a complete sentence or a sentence fragment.

(1) I heard you were a strong student academically. _____

(2) The dog and cat. _____

Action/Linking Verbs

Draw two lines under each verb. On the line, label the underlined verb as action or linking.

(3-4) Have Abigail and Hannah been swimming yet? _____

(5-6) They are excited about the new swimming instructor. _____

(7-8) They have a lot of talent. _____

Draw two lines under each verb. Then, on the blank, indicate whether the verb has active or passive voice.

(9-10) Everything we need is provided for by our parents. _____

(11-12) She loves me so much that she hugged me. _____

Unit # 73 Mastery Score: 12 Minimum Score: 10 Score _____

Fill in the blanks with the missing forms of these regular verbs.

Present	Present Participle	Past	Past Participle
(1-2) Play	(am) _____	played	(have) _____
(3-4) Jump	(is) jumping	_____	(has) _____

Fill in the blanks with the missing forms of these irregular verbs.

Present	Present Participle	Past	Past Participle
(5-6) Swim	(am) swimming	_____	(have) _____
(7-8) Throw	(is) _____	threw	(has) _____

Draw two lines under each verb. Then identify whether the verb tense is present, past, or future.

(9-10) Finally, the girls arrived at the pool. _____

(11-12) They will swim in the shallow end first. _____

(13-14) They certainly do well in their swimming class. _____

Unit # 74 Mastery Score: 14 Minimum Score: 11 Score _____

Draw two lines under each verb. Then on the line identify whether the verb tense is written in present perfect, past perfect, or future perfect tense.

(1-2) The boys have become good mountain climbers. _____

(3-4) The mountains had always seemed too tall to climb. _____

(5-6) They will have become experts in a few years. _____

Unit # 75 Mastery Score: 6 Minimum Score: 4 Score _____

On the line, indicate whether the underlined noun in each sentence is used as a “subject,” “predicate nominative,” “object of preposition,” “direct object,” or “indirect object.”

- (1) When Carolyn was five, she gave her doll to a homeless girl. _____
- (2) She also gave Rebecca a book. _____
- (3) Mark realized that Gracie’s father was dedicated to serving the community. _____
- (4) Hard work left little time for games. _____
- (5) Kyle became Kate’s walking buddy after he met her. _____

Fill in the blanks with the missing forms of these nouns.

	Singular	Singular Possessive	Plural	Plural Possessive
(6-7)	Car	_____	cars	_____
(8-9)	Man	man’s	_____	_____
(10-11)	Sheep	_____	sheep	_____

On the line, identify whether the underlined verb is:
“transitive” (verb has a direct object) or
“intransitive”(verb has no direct object).

- (12) Timmy knows his multiplication tables. _____
- (13) When he recites them, everyone listens. _____

Unit # 76 Mastery Score: 13 Minimum Score: 11 Score _____

Underline the nominative case personal pronoun in each sentence. On the line, identify whether the pronoun is used as a “subject” or “predicate nominative.”

(1-2) What a strong guy is he! _____

(3-4) He can pull a wagon with six kids in it! _____

Underline the objective case personal pronoun in each sentence. On the line, identify whether the pronoun is used as a direct object, indirect object, object of preposition.

(5-6) Have any of you seen him pull the wagon? _____

(7-8) The time Thomas pulled Dad out of the mud gave him such a reputation. _____

(9-10) Thomas’ incredible strength keeps him safe. _____

On the line identify whether the underlined pronoun is a “demonstrative,” “interrogative,” “relative,” or “reflexive” pronoun.

(11) This is the clock that Richard has made. _____

(12) We can thank our parents, whose love for us is very strong. _____

(13) What kind of candy is this? _____

(14) We can enjoy ourselves by telling funny stories. _____

Unit # 77 Mastery Score: 14 Minimum Score: 11 Score _____

Above each underlined word, label (AV) for adverb and (AJ) for adjective.

(1-3) Emily helped her Mom in order to finish the job quickly.

(4-6) The dark stain washed completely out of the white shirt.

On the blank, write the correct degree of comparison for the word at the end of the sentence.

(7) Jacob is the _____ boy in the family. (young)

(8) Matthew is the _____ of everyone. (active)

(9) Andrew's hair is _____ than James'. (blond)

On the line, identify whether the underlined word is used as a preposition, conjunction, or interjection.

(10) I went to the beach by following the sand trail. _____

(11) Help! I keep getting bowled over by the waves. _____

(12) Swimming and building sand castles are the most popular beach activities. _____

Unit # 78 Mastery Score: 12 Minimum Score: 10 Score _____

On the line, identify the underlined word's part of speech—noun, verb, pronoun, adjective, adverb, preposition, interjection, or conjunction.

(1) My most recent story is about Gettysburg. _____

(2) The main character in the story is a young soldier from Harrisburg. _____

(3) He is overwhelmed by the war _____

(4) He wonders how anyone can kill a fellow countryman.

(5) His letters are filled with uncertainty.

(6) Alas! He is unable to escape the terror of the battle.

(7) He throws himself on top of his friend in order to save him.

(8) Both men recovered slowly from the anxiety of the battle.

Unit # 79 Mastery Score: 8 Minimum Score: 6 Score _____

Diagram the following compound and complex sentences.

(1-4) Andrew lifted his sister and she saw the fireworks clearly.

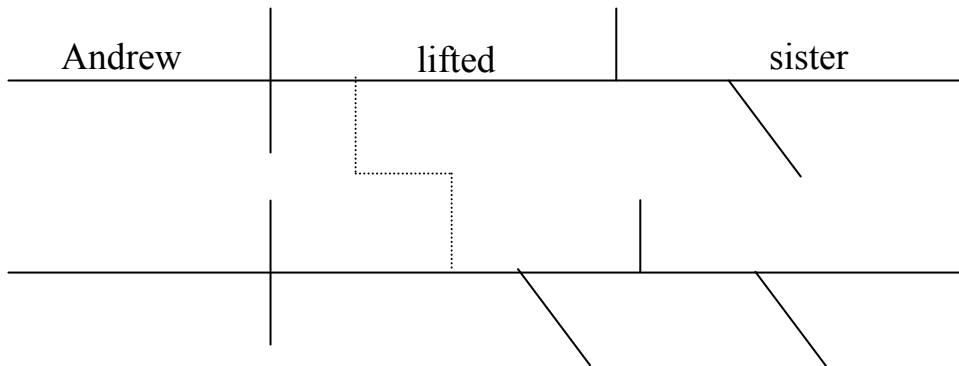

(5-6) Madeline knew what would happen next.

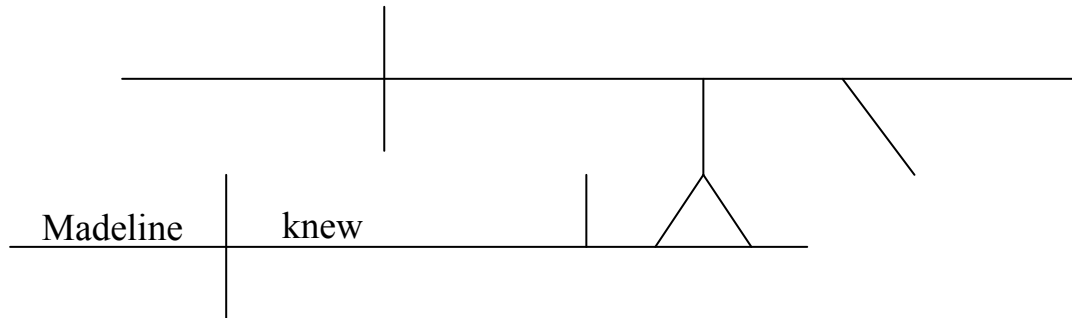

Underline the infinitive in this sentence.

(10) Abigail loves to read biographies.

Underline the participle used as an adjective in this sentence.

(11) The sleeping baby is refreshing herself.

Underline the gerund in this sentence.

(12) Finishing the six-mile race is something to be proud of!

Underline the introductory word of the noun clause.

(13) Can you see what is in the water?

Underline the introductory word of the adjective clause.

(14) The girls, who love to sing, will begin the concert.

Underline the introductory word of the adverb clause.

(15) Hannah sped far ahead, until she tripped over the log.

Unit # 80 Mastery Score: 15 Minimum Score: 13 Score_____

Add quotation marks and end punctuation for each quotation in these sentences.

(1-2) I now pronounce you husband and wife said the officiating minister.

(3-4) What a wonderful day said the new married couple.

Put semicolons, colons, apostrophes, and hyphens where needed in these sentences. One of each is needed.

(5) My sister is very happy she got married today.

(6) She d love to keep all thirty five flowers!

(7) She will fly out for her honeymoon at 6 30

Unit # 81 Mastery Score: 7 Minimum Score: 5 Score _____

In each of the following sentences, draw one line under the subject and two lines under the verb.

(1-2) Max has provided all the party food.

(3-4) Into the hoop, the basketball went.

Label the following sentences as declarative, interrogative, exclamatory, or imperative. Place ending punctuation where needed.

(5) Thomas loves his baby sister _____

(6) Emily, watch out for that wall _____

(7) When was Madeline born _____

(8) Go wash your hands before picking up the baby _____

Label the following sentence as active or passive voice.

(9) The flowers were given as an act of friendship. _____

(10) They gave them the flowers to show their friendship. _____

On the line, identify the sentence as simple, compound, or complex.

(11) James took the clock apart. _____

(12) After pulling out the workings,
he found the problem. _____

(13) The clock needed tightening and
it needed a new battery. _____

(14-24) Proofread the following letter. There are eleven errors.

322 Highland Ave.
Big Heart, MA 55545
january 26, 1999

Deer joshua,

you are cordially invited to a surprise goodbye Party for jacob shelheimer. The party will be held at covered bridge park on Saturdey, February 27, at 11:00 AM. Please respond as soon as possible.

Sincerely,
Mrs. Shelheimer

Write a letter of acceptance for this invitation.

(25) _____

(26) _____

(27) _____

(28) _____

Unit # 82 Mastery Score: 28 Minimum Score: 23 Score _____

Fill in the blank with the correct answer from the list below.

Guide Entry Title

(1) Words listed in alphabetical order in the dictionary are called _____ words.

(2) Words at the top of a dictionary page are called _____ words.

Read the paragraph and place a check beside the sentence that is the topic of the paragraph.

(3) Many senior citizens find themselves feeling lonely and forgotten. Often, they do not know where to turn for comfort. We can help by taking the time to show that we care. If you know an older person who lives alone or in a nursing home, visiting them might be just the thing to cheer them up. By making an effort to talk and laugh with them regularly, after awhile they may not feel lonely anymore!

_____ Many people are lonely

_____ By spending time with older people, we have the ability

to help them feel loved and appreciated.

_____ Laughing with someone makes us happy.

Unit # 83 Mastery Score: 3 Minimum Score: 2 Score _____

Read the following paragraphs and answer the questions below.

Jacob couldn't believe the beauty of the ocean. The calm, lapping waves moved gently into the golden sand. As he gazed across the deep waters, he admired the soft orange hues of the setting sun. The peaceful scene made him feel rested and refreshed.

There are many techniques for stopping the hiccups. Some believe you must simply hold your breath; others say it is best to drink water; and still others are convinced you simply need to stand on one foot. In my opinion, the best way to stop the hiccups is a combination of many methods. First, get a glass of water. Then, lay down and have someone plug your ears while you hold your breath. After 30 seconds, drink the water while your assistant continues to plug your ears. It works every time!

(1) The first paragraph was (a description, an explanation).

(2) The second paragraph was (a description, an explanation).

(3-18). Decide which of these are the main topics, sub-topics, and points and complete the outline.

II] Write an outline.

A. Select a topic that interests you.

C. Arrange the ideas in the best order.

1. Cross out each part of the outline as you write it in your composition.

III] Write your rough draft.

A. Make sure the composition is in the best order

I] Choose an interesting topic.

B. Use strong transitions between points to help the composition flow smoothly.

1. The more interested you are, the more you will enjoy writing about your topic.

C. Check that each sentence is clear and complete.

B. Select a topic for which you can find information.

C. Write clear sentences.

2. Cross out the ideas that will not support your topic well.

A. Follow your outline.

B. Choose ideas that best support your topic.

C. Select a topic that you know well.

A. Pre-write by writing down all of your ideas.

B. Make sure each sentence supports the topic.

1. Highlight the ideas you want to use.

IV] Revise

How to Write a Composition

I] Choose an interesting topic

1. _____

II] Write an Outline

III] Write the Composition

IV] Revise

<p>Unit # 84 Mastery Score: 13 Minimum Score: 11 Score _____</p>

On the line write “sentence” or “fragment” to indicate whether the group of words is a complete sentence or a sentence fragment.

(1) I want to be an honest leader. _____

(2) Unto me. _____

(3) I should be a good example to other students. _____

(4) Had the correct spelling. _____

(5) His hope for the future. _____

Place the correct punctuation after each sentence. On the line indicate whether the sentence is declarative, interrogative, exclamatory, or imperative.

(6) Which famous authors have we studied this year _____

(7) The stories were based upon mythical characters _____

(8) How much we appreciate her character _____

(9) Remember – that was your homework assignment _____

Draw one line under the subject and two lines under the complete verb in each sentence.

(10) A friend found Mr. Harrison’s books.

(11) Once, because of a robbery, all of his valuables were taken from his home.

In each sentence draw one line under the subject and two lines under the verb or helping verb that agrees in number with the subject.

(12) Into the park (goes, go) two fishermen.

(13) Andrew and Michael (is, are) avid fishermen.

Diagram the compound subject and the verb of this sentence.

(14-17) Andrew and Michael went to the lake.

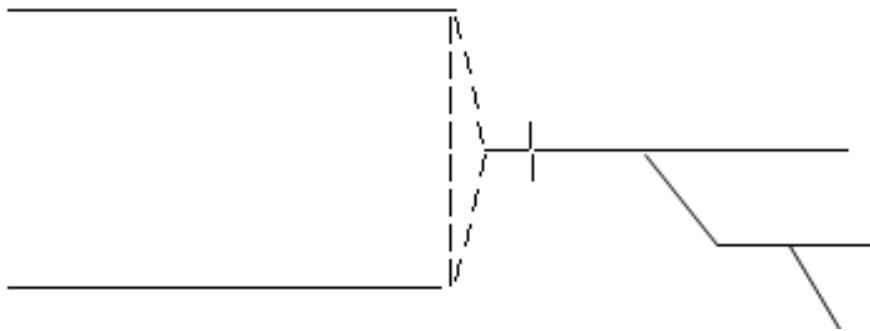
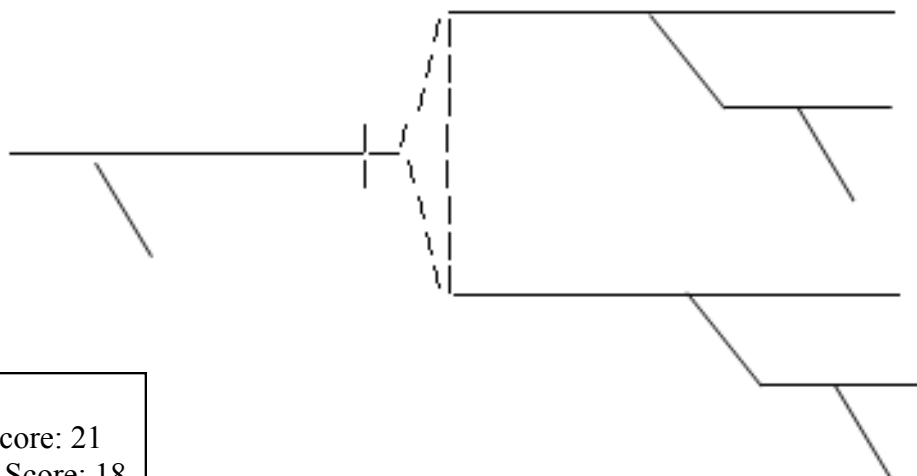

Diagram the subject and the compound verb of this sentence.

(18-21) The boys fish in the lake and wander along the trails.



Unit # 85 Mastery Score: 21 Minimum Score: 18 Score _____

Draw two lines under each verb in the sentence. On the line, indicate whether the verb is action or linking.

1-2. Young Andrew was surrounded by nature. _____

3-4. Andrew remained a happy fisherman. _____

Diagram the sentences below.

5. Andrew loves the forest

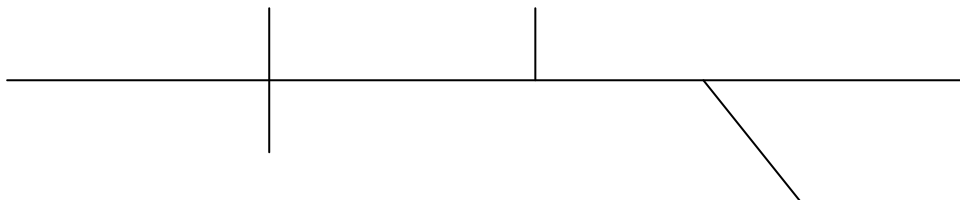

6. Andrew wrote a letter to his friend.

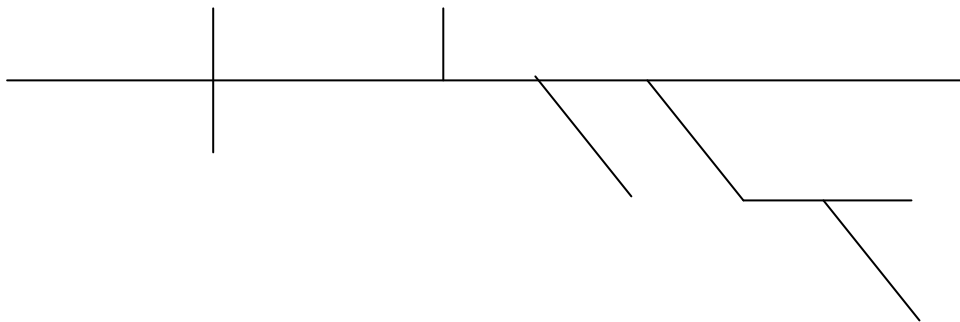

7. Andrew sent Peggy a letter of comfort

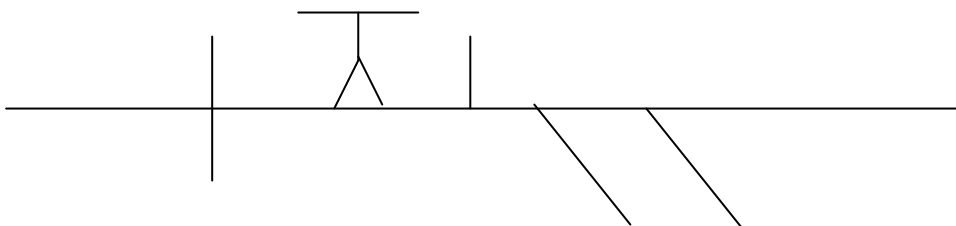

Draw one line under the subject and two lines under the linking verb.

(8) A motivated worker is not lazy.

(9) Andrew was a motivated, dependable student in the classroom.

A line has been drawn under the verb. On the line, indicate whether the verb is transitive or intransitive.

(10) Andrew dusts the shelves and books in the classroom. _____

(11) Andrew also works in the bookstore down the street. _____

Draw two lines under each verb. On the line, indicate whether the verb is active or passive.

(12-13) Sometimes Andrew catches fish. _____

(14-15) Andrew is taught the necessary fishing skills
by his father. _____

Unit # 86 Mastery Score: 15 Minimum Score: 13 Score _____

Complete this chart by giving the missing forms of these regular and irregular verbs.

	<u>Present</u>	<u>Present Participle</u>	<u>Past</u>	<u>Past Participle</u>
(1-3) lay	_____	_____	_____	_____
(4-6) freeze	_____	_____	_____	_____
(7-9) open	_____	_____	_____	_____
(10-12) help	_____	_____	_____	_____

Draw two lines under the correct verb form.

- (13) The water froze in the pipe and (broke, busted) it.
- (14) The squirrels have food now that winter has (come, came).
- (15) The raccoon (stoled, stole) food from the dog's dish.

Draw two lines under each verb. On the line, indicate whether the verb is the present, past, or future tense.

- (16) Who helps my mother? _____
- (17) What will become of the squirrel this winter? _____
- (18) Uncle Lou inspired me to become a teacher. _____

Unit # 87
 Mastery Score: 21
 Minimum Score: 18
 Score _____

The verb in each sentence is underlined. Indicate whether the tense of the verb is present, past, future, present perfect, past perfect, or future perfect.

(1) Andrew heard his father's instructions. _____

(2) He will learn those new lessons taught. _____

(3) Andrew is fishing in the lake today. _____

(4) Andrew enjoys fishing as much as his father. _____

(5) Andrew's father had fished in the same lake when he was young. _____

(6) A member of their family will have fished in this lake for fifty years. _____

Fill in the correct tense of the verb in the person indicated.

help helping helped helped

(7) I _____ present

(8) I _____ past

(9) I _____ future

(10) I _____ present perfect

(11) I _____ past perfect

(12) I _____ future perfect

go going went gone

(13) I _____ present

(14) I _____ past

(15) I _____ future

(16) I _____ present perfect

(17) I _____ past perfect

(18) I _____ future perfect

Draw two lines under the correct form of the verb in the sentence.

(19) Who (taught, learned) Andrew to fish?

(20) Andrew (set, sat) down to rest while he fished.

(21) He (lets, leaves) his sister come to the lake with him.

(22) Andrew (laid, lain) his fishing rod on the ground.

(23) He (rose, raised) from his seat to check the fish he had caught.

(24) Andrew (left, let) the lake at noon.

<p>Unit # 88 Mastery Score: 24 Minimum Score: 21 Score _____</p>

On the blank, write “subject,” “predicate nominative,” “direct object,” “indirect object,” “object of preposition,” “appositive” or “direct address” to show how the underlined noun in each sentence is used.

(1) Andrew was a boy who loved to fish. _____

(2) His friends liked to go fishing with him. _____

(3) He gladly gave his sister his best fishing rod. _____

(4) Michael, a good friend, also liked to go fishing. _____

(5) He also liked to fish at the lake. _____

(6) Catching fish brought great happiness to both boys . _____

(7) “Oh, Andrew,” said Michael, “I will see you at the lake again tomorrow.” _____

Write the singular possessive, plural, and plural possessive of each noun.

	<u>Singular</u>	<u>Singular Possessive</u>	<u>Plural</u>	<u>Plural Possessive</u>
(8-10) potato	_____	_____	_____	_____
(11-13) man	_____	_____	_____	_____
(14-16) story	_____	_____	_____	_____
(17-19) mouse	_____	_____	_____	_____

Draw two lines under the correct form of the verb in each sentence.

(20) Andrew (has, have) been fishing at the lake.

(21) Andrew and Michael (love, loves) to be together at the lake.

(22) One story Andrew's father tells (is, are) about the "big fish that got away."

(23) The boys always (run, runs) back home to tell about their day at the lake.

(24) "These boys (remind, reminds) me of my youth," said Andrew's father.

Unit # 89 Mastery Score: 24 Minimum Score: 22 Score _____

Write NC for nominative case, OC for objective case, or PC for possessive case above each personal pronoun.

(1-2) James made an excellent choice, and by following his example, I can learn much about leading a dedicated life.

(3-5) Good advice inspired him, and I will base all my decisions on wisdom, too.

Underline the correct word in each sentence.

(6) James learned that (its, it's) wise to follow good examples.

(7) When you follow good examples, (you're, your) living your life the way it was meant to be.

(8) When people do the right thing, (their, they're) to be rewarded.

Draw two lines under the antecedent for each italicized pronoun.

(9) Father tells stories about *his* fishing experiences.

(10) Andrew thought a new fishing rod would greatly help *him* catch more fish.

(11) Michael and Andrew enjoyed *their* fishing adventures.

Write “demonstrative,” “interrogative,” “relative,” “reflexive,” or “indefinite” on the line to show what kind of pronoun the underlined word in each sentence is.

(12) Whose basket of flowers is this? _____

(13) Everyone can learn from their past experiences. _____

(14) Andrew helped himself to more vegetables at lunch. _____

(15) We must help those who are not as fortunate. _____

(16) These are two important items we must not forget. _____

<p>Unit # 90 Mastery Score: 16 Minimum Score: 13 Score _____</p>

On the line, show whether each underlined word is used as a noun, a verb, a pronoun, an adjective, an adverb, a preposition, a conjunction, or an interjection.

- (1) Father was invited to assist the boys on a fishing trip. _____
- (2) When fully assured he would help, the boys were elated. _____
- (3) Even though the trip was short, they had a good time. _____
- (4) Thinking ahead, Father took lunch to the lake. _____
- (5) Eventually they went fishing, and they caught several large fish.

- (6) The lake was known for having a large picnic grove. _____
- (7) Yes, Father enjoyed the trip as much as the boys did. _____
- (8) He was thrilled to be included in their fun at the lake. _____

Underline the correct degree of comparison in each sentence.

- (9) Tell us about the (more, mucher, most) interesting story you have ever read.
- (10) The lake was (calm, calmer, calmest) than yesterday.
- (11) The trips became (enjoyable, more enjoyable, most enjoyable) each time they went.

Underline the adjectives in the sentences.

- (12) Andrew and Michael, excited and happy, prepared for the next fishing trip.
- (13) The puppy left a large, muddy print on the kitchen floor.

Underline the adverbs in the sentences.

(14) Mother soon discovered the muddy puppy.

(15) Even though he had made a mess, she still loved him.

Diagram the following sentences.

(16) All students should read daily from their favorite books.

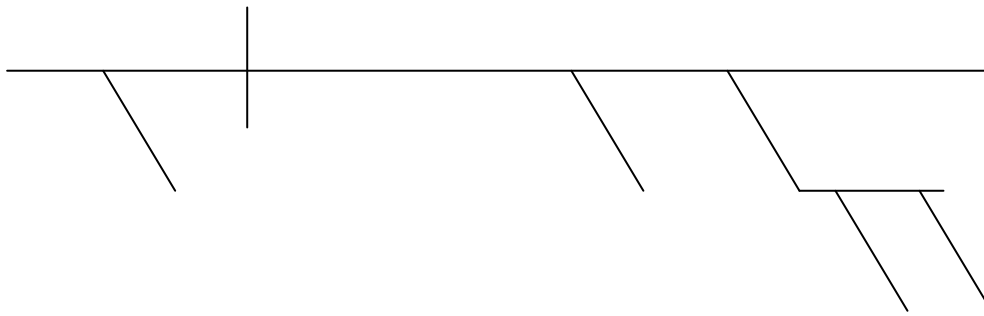

17. The cost of the corn is written under the shelf.

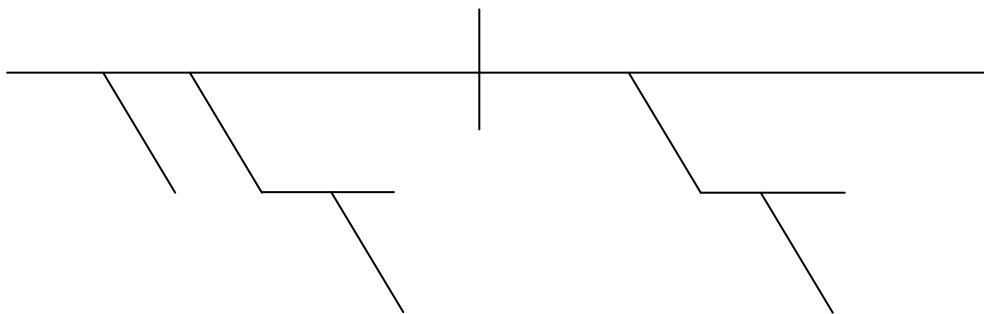

Unit # 91 Mastery Score: 17 Minimum Score: 14 Score _____

Identify each underlined word as a “noun,” “verb,” “pronoun,” “adjective,” “adverb,” “preposition,” “conjunction,” or “interjection.”

(1) For Andrew, every day at the lake was full of exciting adventures. _____

(2) My, how he looked forward to each trip! _____

(3) There, he enjoyed fishing. _____

(4) Later in the day, this enjoyment proved to be very satisfying. _____

(5) When Andrew was thirteen, he was given more responsibility. _____

(6) Father appointed him head fisherman of the family. _____

(7) Later, he took his sister to the lake and taught her how to fish. _____

(8) His patience was rewarded, and Father honored his sincere efforts. _____

Diagram these sentences.

(9) The results of his patience were clearly seen in his sister’s ability.

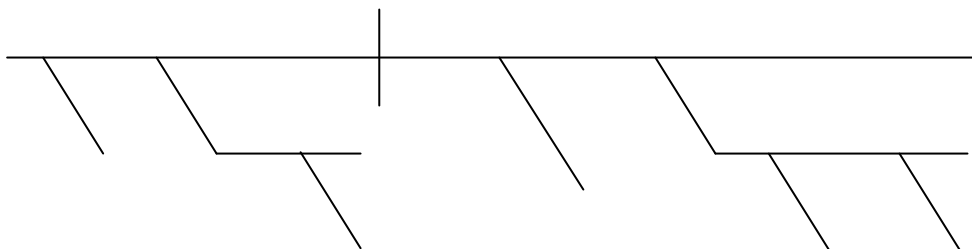

(10) He anxiously sought his father's opinion in this decision.

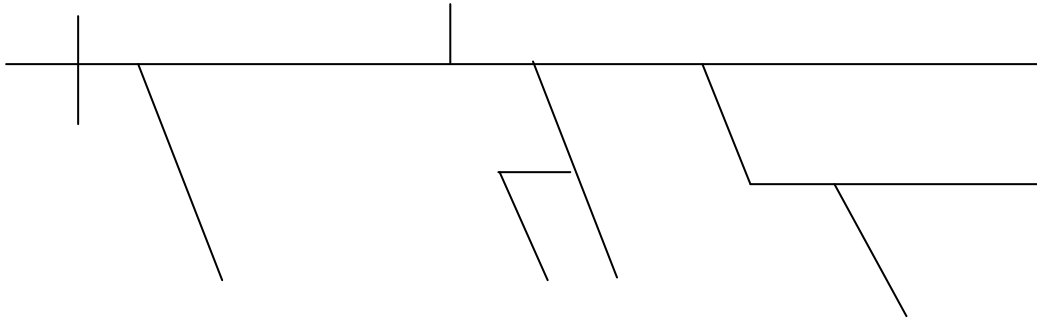

Unit # 92
Mastery Score:10
Minimum Score: 8
Score _____

Diagram this compound sentence.

(1-10) The game amazes me; therefore, I must practice every day.

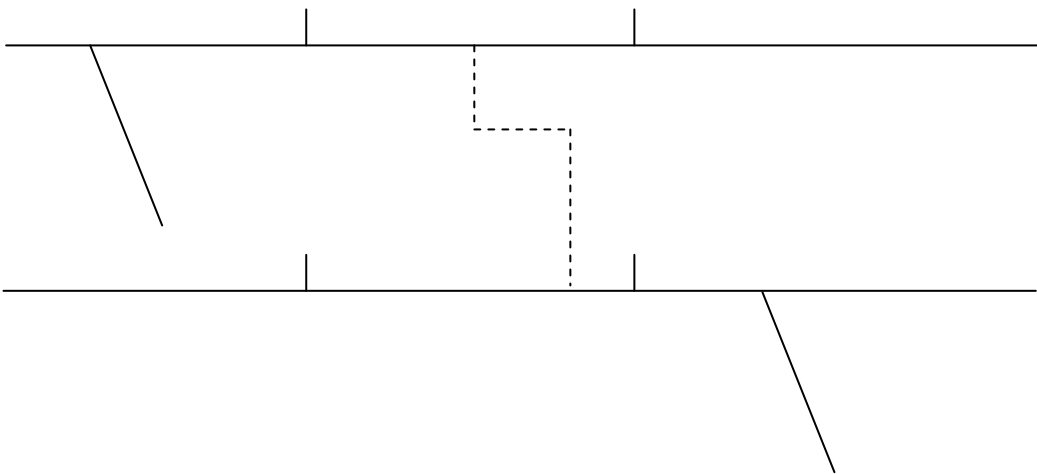

11-20. When the boys were children, their parents nurtured their many talents.

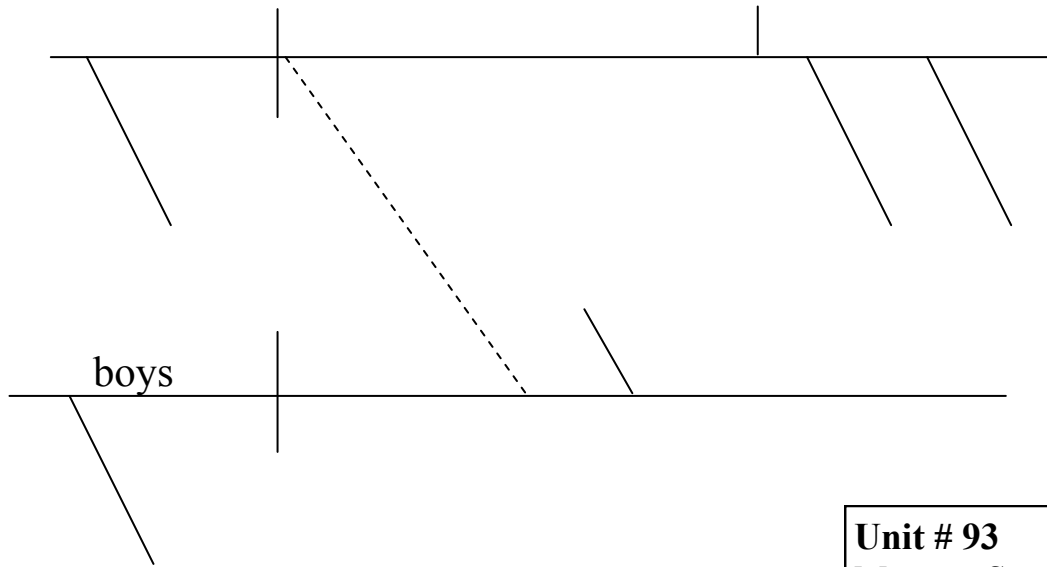

Unit # 93 Mastery Score: 20 Minimum Score: 16 Score _____

On the line write “S,” “F,” or “R” to show whether the group of words is a complete sentence, a sentence fragment, or a run-on sentence.

- _____ 1. Out on the lake a raging storm big waves.
- _____ 2. Brave Andrew was frightened by the storm, his younger sister was also extremely frightened.
- _____ 3. Finally the storm passed and all was calm.

Match the following.

_____ (4) expository paragraph

A. states the topic of a paragraph

_____ (5) paragraph

B. states an opinion

_____ (6) narrative paragraph

C. explains an idea, gives information, or tells how to do or make something

_____ (7) topic sentence

D. describes people, places, experiences, or feeling

_____ (8) descriptive paragraph

E. tells a story

_____ (9) persuasive paragraph

F. sentences about one idea or topic

Unit # 94 Mastery Score: 9 Minimum Score: 7 Score _____

Add the end punctuation, quotation marks, and commas as needed in the following sentences.

(1-3) You are a wonderful fisherman exclaimed Father after the fishing trip

(4-6) Andrew smiled and asked Do you really think so

(7-11) Yes commented Father expectantly I certainly do

Add underlines, quotation marks, apostrophes, hyphens, and dashes where needed in the following sentences.

(12-13) The book Swiss Family Robinson tells us about the Robinsons life on the island.

(14-15) Diligence, dedication, and character these are just a few words used to describe the well known person.

(16) Andrew enjoys singing the song The Star Spangled Banner.

In each of the following groups, underline the option that is correctly punctuated and capitalized for a friendly letter or a business letter.

(17) a. Dear sir,
b. Dear Sir:

(18) a. 123 Uplift Lane
Uplift City, Uplift 99999
June 30, 1999

(19) a. Dear Friend,
b. Dear Friend:

b. 123 uplift lane
Uplift City, uplift 99999
June 30, 1999

(20) a. Your Friend,
b. Your friend,

Unit # 95 Mastery Score: 20 Minimum Score: 18 Score _____

End of English Diagnostic
Units 61-96

Revised 12/18/09