

PROCEDURE

To determine the number of teeth on a gear: the ratio of the number of teeth on two drive gears is *inversely* related to the ratio of their respective r.p.m. (revolutions per minute).

$$\frac{\text{No. teeth gear 1}}{\text{No. teeth gear 2}} = \frac{\text{r.p.m. gear 2}}{\text{r.p.m. gear 1}}$$

Model 1: A transmission main drive gear has 25 teeth and rotates 500 r.p.m. It drives a countershaft drive gear at 250 r.p.m. How many teeth does the countershaft drive gear have?

$$\frac{25}{\text{No. teeth gear 2}} = \frac{250}{500}$$

No. of teeth on gear 2 = 50.

Model 2: In first gear, or low gear, an automobile's engine runs about three times as fast at the propeller shaft. In second gear, the engine does not have to run as fast; usually it runs about $1\frac{2}{3}$ times faster than the propeller shaft. Finally, in third, or high gear, the engine runs at the same speed as the propeller shaft.

Suppose an engine is running 2,000 r.p.m. in second gear. How fast is the propeller shaft running?

$$2,000 \div 1\frac{2}{3} = 2,000 \times \frac{3}{5} = 1,200 \text{ r.p.m.}$$

PROCEDURE

To determine the mechanical advantage of a particular machine, use the following guidelines: the ideal mechanical advantage of a machine = distance ratio = distance moved by a force operating a machine divided by distance load moved.

The preceding procedure may be utilized in several machine relationships involving distance, force, speed, and weight. The following models are three such examples.

Model 1: Fulcrums

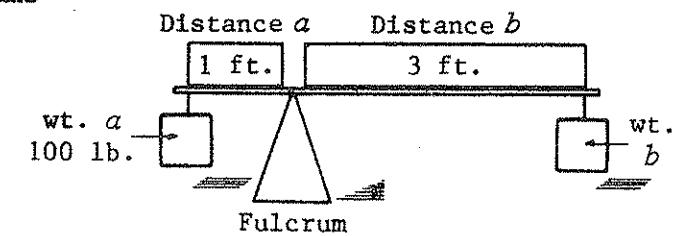

If the two weights on this fulcrum are balanced, then the unknown weight must be $33\frac{1}{3}$ lb.:

$$\text{weight}_a \times \text{distance}_a = \text{weight}_b \times \text{distance}_b$$

$$100 \times 1 = \text{wt.}_b \times 3$$

$$\text{wt.}_b = \frac{100}{3} = 33\frac{1}{3} \text{ lb.}$$

Model 2: Pulleys

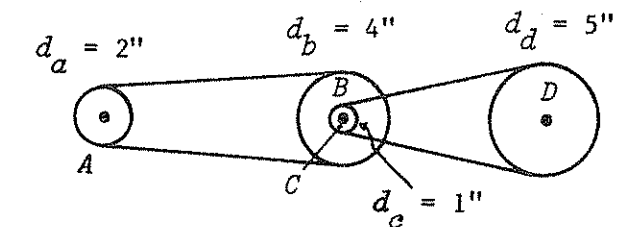

The r.p.m. of each pulley is related to its diameter. Thus, if pulley A, which has a 2" diameter, rotates at 500 r.p.m., then pulley B, which has a 4" diameter, or twice the diameter of pulley A, must rotate at one-half the speed of pulley A, or 250 r.p.m.

$$\frac{d_a}{d_b} = \frac{\text{r.p.m.}_b}{\text{r.p.m.}_a}$$

$$\frac{2}{4} = \frac{\text{r.p.m.}_b}{500}$$

$$\text{r.p.m.}_b = \frac{1,000}{4} = 250 \text{ r.p.m.}$$

Pulley C's diameter is 1"; but, because pulley C is keyed to the same shaft as pulley B, it has to rotate at the speed of B, or 250 r.p.m. Pulley C drives pulley D, whose diameter is 5". Then, for pulley D

$$\frac{d_c}{d_d} = \frac{\text{r.p.m.}_d}{\text{r.p.m.}_c}$$

$$\frac{1}{5} = \frac{\text{r.p.m.}_d}{250}$$

$$\text{r.p.m.}_d = \frac{250}{5} = 50 \text{ r.p.m.}$$

Model 3: Axles

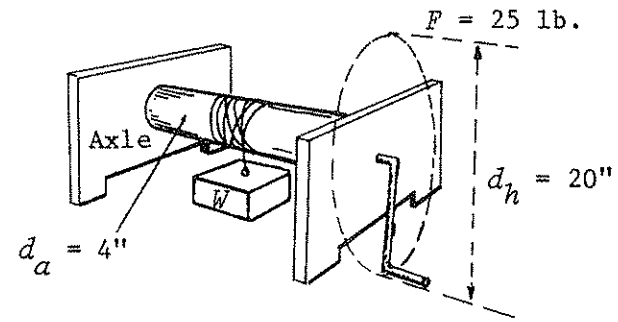

The axis of the handle is the diameter of the circle formed by moving the handle around one complete turn. In this case, the diameter is 20 inches. F , which is the force exerted on the handle to lift the weight, is 25 pounds. The diameter of the axle if 4". To figure how much the weight weighs, use the following equation and compute as shown.

$$F \times d_h = W \times d_a$$

$$25 \times 20 = W \times 4$$

$$W = \frac{500}{4} = 125 \text{ lb.}$$

Solve the following automotive-services problems based on the examples shown previously.

- 3.1 Voltage = 18 v
Current = 36 amps
Resistance = ?

- 3.2 Voltage = 12 v
Current = 48 amps
Resistance = ?

- 3.3 Resistance = 0.1 ohm
Current = 60 amps
Voltage = ?

- 3.4 Voltage = 120 v
Current = 50 amps
Resistance = ?

- 3.5 Engine speed = 1,850 r.p.m.
Transmission in second gear
Propeller-shaft speed = ?

- 3.6 Engine speed = 2,100 r.p.m.
Transmission in first gear
Propeller-shaft speed = ?

- 3.7 Engine speed = 2,400 r.p.m.
Propeller-shaft speed = 2,400 r.p.m.
Transmission in which gear?

- 3.8 Propeller-shaft speed = 650 r.p.m.
Transmission in first gear
Engine speed = ?

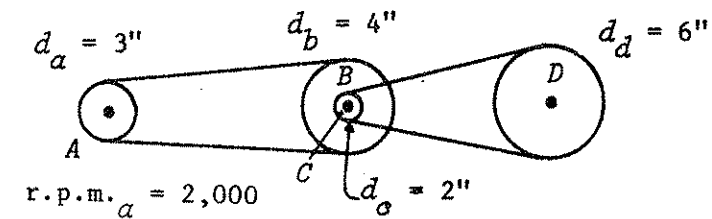

- 3.9 In this pulley diagram how fast do pulleys B and C rotate, assuming they are keyed together?

- 3.10 Based on your answer in Problem 3.9, how fast must pulley D rotate?

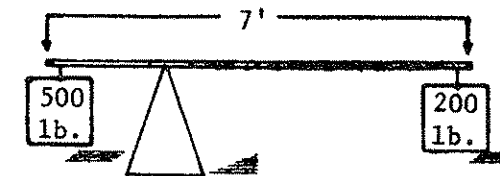

- 3.11 In this fulcrum the weights are perfectly balanced. How far must the fulcrum be located from the 200 lb. weight if the bar is 7 feet long?

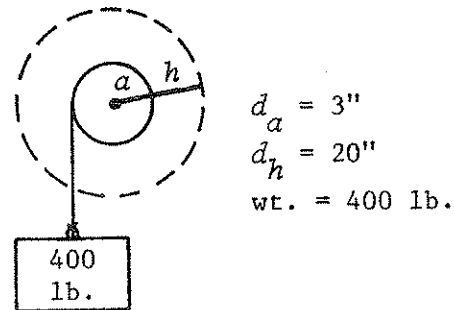

3.12 Given this axle, how much force must be used to lift the weight?

FOOD SERVICES

Two of the responsibilities that restaurants and cafeterias have are to know how many cases of canned foods and how many pounds of meat are needed to feed their customers. This section explains how to determine these questions.

PROCEDURE

To determine the number of cases of a certain canned food item needed to feed diners, multiply the number to be served by the size of the individual portion. Then divide the resulting figure by the capacity of a standard can of the food item. Finally, divide the resulting number of cans needed by 12 to obtain the number of cases.

Model 1: You serve 380 customers at dinner. You plan to serve tomato juice, which comes in 46 oz. cans. Assuming you plan to serve each customer a 5 oz. portion, how many cases of tomato juice will you need?

$$\text{No. of ounces needed} = 380 \times 5 = 1,900$$

$$\text{No. of cans needed} = \frac{1,900}{46} = 41.3, \text{ or } 42 \text{ cans}$$

$$\text{No. of cases needed} = \frac{42}{12} = 3.5$$

Model 2: A #10 can yields 120 oz. of pineapple. You plan to give each diner an 8-oz. portion. You estimate you will feed 240 patrons. How many #10 cans will you need?

$$\text{No. of ounces needed} = 240 \times 8 = 1,920$$

$$\text{No of \#10 cans needed} = \frac{1,920}{120} = 16$$

PROCEDURE

To calculate the number of pounds of meat required to feed diners, for poultry divide the number to be served by 2.5; for meat with little or no bone, divide the number to be served by 3.5; and for fish fillets divide the number to be served by 3.5.

Model 1: Your restaurant serves ground round steak. You estimate you will serve 150 patrons in any given day. How many pounds of round steak should you prepare?

$$\text{No. of pounds} = \frac{150}{3.5} = 42.86, \text{ or } 43 \text{ lb.}$$

Model 2: You have prepared 50 lb. of fish fillets for the dinner meal. You serve 125 customers. Do you have enough fish prepared?

$$\text{No. of servings} = 50 \times 3.5 = 175$$

You have an excess of 50 servings, so the answer is yes.

Perform the following calculations based on the food-service section.

3.13 No. of diners = 250
Portions of juice served = 4 oz. per diner
Size of juice can = 48 oz.
How many cases of juice required?

3.14 Size of juice can = 44 oz.
Portions of juice served = 6 oz.
Number of cases used = 2
How many patrons can be served?

3.15 No. of patrons = 225
Portions of beets served = 8 oz.
Size of beet can = 45 oz.
How many cans of beets required?